



Steam sootblowers

Water cannons

Product catalogue

Power of innovative ideas

Powerz

We manufacture:

- Water cannon sootblowers
- Steam sootblowers

Our sootblowers are designed for the preventive cleaning (on the gas side) of the heating surfaces of operating steam boilers burning solid or liquid fuel or biomass. Cleaning is performed to maintain the boiler unit in an operating clean condition, which allows you to maintain boiler efficiency within the design limits, as well as extending the service life of the boiler and reducing the cost of its repair.

About us

Powerz is an innovative international company specialized on engineering solutions in the field of thermal power, oil-gas and chemical industries.

Our head office is located in Germany and is the main centre for the implementation of projects for the installation of boiler cleaning systems.

Using of innovative technologies allows the Powerz sootblowers to accurately clean the boiler without interrupting its operation for deslagging and cleaning of the heating surfaces. The engineers are very scrupulous about getting their jobs done, designing optimum solutions taking into account all requirements to fully satisfy the needs of the customer. Experience, knowledge and application of its own developments allow Powerz to remain the indisputable leader on the power equipment market.



POWERZ® sootblowers are the result of years of development efforts of its engineers. Nowadays Powerz has a wide range of highperformance equipment designed to clean the boiler under load and remove the remains of the combustion process. Using of innovative technologies and the sophisticated geometry of the blowing nozzles ensures high-quality cleaning of various parts of the boiler.

Basic concepts

The water cannon and steam sootblowers are designed for the preventive cleaning (on the gas side) of the heating surfaces of operating steam boilers burning solid or liquid fuel or biomass. Cleaning is achieved by moving jets of water or steam which are formed and transferred towards the surface being cleaned by means of the nozzles of the sootblowers.

The necessity to clean a heating surface of a steam boiler is determined individually in each case and depends on the boiler's assembly features, mineral composition of the fuel used, and gas temperature and speed in accordance with conditions providing operating pure state of the surface.

In order to provide stable functioning of the entire system, steam boilers are equipped with a comprehensive cleaning system which is designed by the specialists for specific conditions and includes specialised cleaning units for individual heating surfaces.

The use of sootblowers helps to increase operating availability of the boiler unit, decrease downtime and repair expenses, and increase the unit's performance up to projected parameters and efficiency.

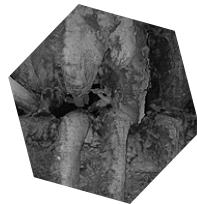
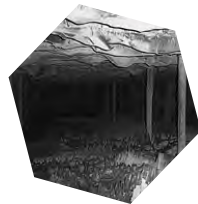
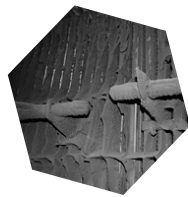

Problem statement

Physical manifestation of negative factors of ash deposition:

Sticking of ash to the external surface of pipes; ash has a low heat transfer coefficient and provokes a sharp drop in the heat transfer coefficient from the combustion products to the heat carrier (water or steam).

Negative factors of ash deposition are:

- decrease of boiler unit's performance;
- reduction of the operating efficiency as a result of increasing the temperature of the exhaust gases, which in turn leads to excessive fuel consumption;
- increased auxiliary electricity requirements when smoke exhausts are operating at a peak load due to the increase of the air-flow resistance of the heat exchange unit packages, since the area of passage also decreases;
- unscheduled shutoffs of boiling units due to contamination of heat exchange units' surfaces;
- damage of boiling units' components due to collapse of accumulated ash blocks;
- significant deposition of unburned fuel particles on convective heating surfaces (economiser, air preheater) can lead in the future to their ignition, which causes damage to the components of the boiler unit.

Improper operation and delayed cleaning of the boiler unit can lead to an emergency failures. The most common causes leading to an accident are: fuel explosion, fine water filter clogging, drop in boiler water pressure, mechanical damage to pipes, failure to follow heating requirements, violations of blowing protocol, pressure decrease. POWERZ® sootblowers may eliminate possible negative factors and may help reach the design parameters of boiling units.

Powerz develops and offers comprehensive solutions that include fine-tuned sootblowers, an automatic control system, valves, instrumentation, as well as services for installation supervision, and chef commissioning of the supplied equipment.

POWERZ® sootblowers: application areas

ASO-W L1
Long-range water cannon sootblower

Combuster walls (combuster)

ASO-W L1
Long-range water cannon sootblower

ASO-W L1
Short-retractable steam sootblower

Platen steam superheaters

Furnace unit hard-to-reach areas

ASO-WS
Short-retractable water cannon sootblower

Curtain walls and convective heating surfaces

ASO-SL
Long-retractable steam sootblower

Water economiser

Air preheaters

ASO-SP
Partially-retractable steam sootblower



Steam sootblowers

Determination of sootblower type and its blowing parameters is based on:

- Design of furnace burner arrangement
- Size of the furnace
- Intensity
- Nature of impurity







The Powerz engineers select the optimal cleaning unit for each boiler unit individually.

Consultation with a qualified engineer allows you to determine finally the type of the device to achieve the planned result of its operation.

Steam blowers have a travel range of up to 12 metres and are used to clean the boiler heating surfaces, furnace walls, water economiser and air preheaters.

Steam sootblowers

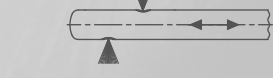
Types of steam-blowing | Operating medium - steam

Name	Designation	Description	Travel range, m	Operating medium pressure, MPa	Cleaning area	Operating temperature, °C	Blowing nozzle dia, mm	Operating principle
Long-retractable steam sootblower	ASO-SL	<ul style="list-style-type: none"> used for cleaning of curtain walls and convective heating surfaces of the boiler 	1,5–12,0	1,0–4,0	360°	340–400	8–30	
Short-retractable steam sootblower	ASO-SS	<ul style="list-style-type: none"> used for cleaning the furnace walls throughout the height of the boiler furnace used for cleaning the water economiser and boiler air preheaters of the boiler 	до 0,5	0,8–3,0	360°	350	8–30	
Partially-retractable steam sootblower	ASO-SP	<ul style="list-style-type: none"> the blowing tube remains partially in the internal space of the boiler unit used for cleaning individual segments of heating surfaces 	6,0–12,0	1,0–4,0	360°	320–400	8–30	
		<ul style="list-style-type: none"> the blowing tube makes pendular rotational movements 	1,5–9,0	1,0–4,0	360°	340–400	8–30	
Pendulum steam sootblower	ASO-SPN	<ul style="list-style-type: none"> used for cleaning heating surfaces 	1,5–9,0	1,0–4,0	360°	340–400	8–30	
Non-rotating steam sootblower	ASO-SNR	<ul style="list-style-type: none"> the blowing tube does not rotate used for cleaning heating surfaces 	1,5–9,0	1,0–4,0	360°	340–400	8–30	
Stationary steam sootblower	ASO-S0	<ul style="list-style-type: none"> the blowing tube is completely located in the internal space of the boiler unit and only makes rotational movements 	1,5–9,0	1,0–4,0	360°	340–400	8–30	

ASO-SL

Long-retractable steam sootblower

The long-retractable steam-blowing unit is intended for cleaning curtain walls and convective heating surfaces of boiler units from deposits of ash, as well as for cleaning water economisers and air preheaters of boilers from impurities.

Cleaning is carried out by a blowing tube with a nozzle head which partially remains in the jacket space of the boiler unit, by using kinetic energy of highspeed steam jets under pressure from 1MPa to 4 MPa and operating temperature from 340°C to 400°C, coming out of the nozzles and directed onto the contaminated heating surface. The travel range is from 1.5 to 12 metres.

The long-retractable steam sootblower can carry out blowing either along the entire length of the forward and reverse stroke of the nozzle head introduced into the flue-gas duct or only in certain areas of its stroke.

It is used for cleaning platen and convective steam superheaters, and water economisers.

Operating medium - steam
P=1.0 MPa to 4.0 MPa and T=340°C to 400°C.

ASO-SS

Short-retractable steam sootblower

The short-retractable steam sootblower is intended for external cleaning of furnace walls throughout the height of the furnace. The cleaning effect is achieved by using the kinetic energy of the steam jet at a pressure of 0.8MPa to 3MPa and an operating temperature of 350°C, coming out of the nozzles and directed onto the contaminated surfaces of the furnace walls.

Blowing covers the entire surface of the furnace wall, and therefore the number of blowing units per boiler is determined by the size of the furnace wall surface and the effective operating range.

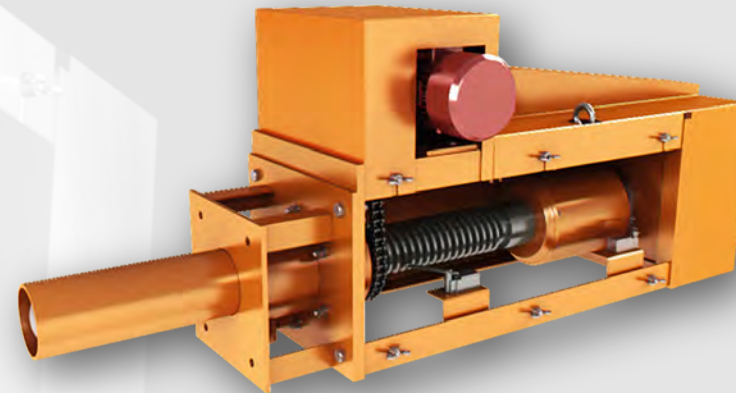

It is used for cleaning furnace walls throughout the height of the furnace.
Operating medium - steam
P=0.8MPa to 3MPa and T=350°C.

The water cannon sootblower is used for cleaning the furnace walls of external ash deposits. Long-range and retractable water-blowing units of various types can be used both independently and in combination with each other to improve the cleaning efficiency and greater coverage of the furnace walls. Long-range and retractable water cannons of various types can be used both independently and in combination with each other to improve the cleaning efficiency and greater coverage of the furnace walls.

Water cannons



ASO-WL1



ASO-WL2



ASO-WS

Operating medium - water

Name	Designation	Description	Travel range, m	Operating medium pressure, MPa	Cleaning area	Operating temperature, °C	Blowing nozzle dia, mm	Operating principle
Long-range water cannon	ASO-WL1 ASO-WL2	<ul style="list-style-type: none"> used for cleaning the furnace walls throughout the height of the boiler furnace 	up to 30	1,0-3,0	90° in horizontal and vertical direction	up to 50	8-20	
Short-range water cannon	ASO-WS	<ul style="list-style-type: none"> used for cleaning furnace walls in the area of the platen steam superheater and other hard-to-reach places of the boiler furnace 	—	1,0-2,0	360°	up to 50	8-20	

ASO-WL1

Long-range water cannon

The long-range water cannon carries out jet-washing of the furnace side by reversing oscillating motions of the jet in the direction of pollution along the predetermined path.

For the ASO-WL1 type the cleaning area is directed in horizontal and vertical directions at an angle of 90°. The operating pressure of such type is from 1 to 3 MPa, temperature up to 50°C.

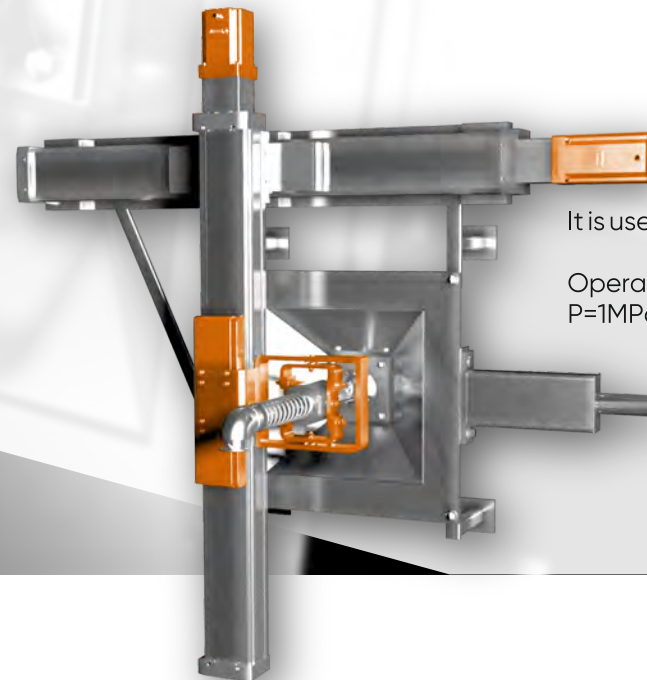

It is used for cleaning furnace walls.

Operating medium - water
P=1MPa to 3MPa and T=50°C.

ASO-WL2

Long-range water cannon

The long-range water cannon carries out jet-washing of the opposite side of the furnace by reversing oscillating motions of the jet in the direction of pollution along the predetermined path.

For ASO-WL2 type the cleaning area is directed in horizontal and vertical directions at an angle of 90°. The operating pressure is from 1 Mpa to 3 MPa, operating temperature up to 50°C.

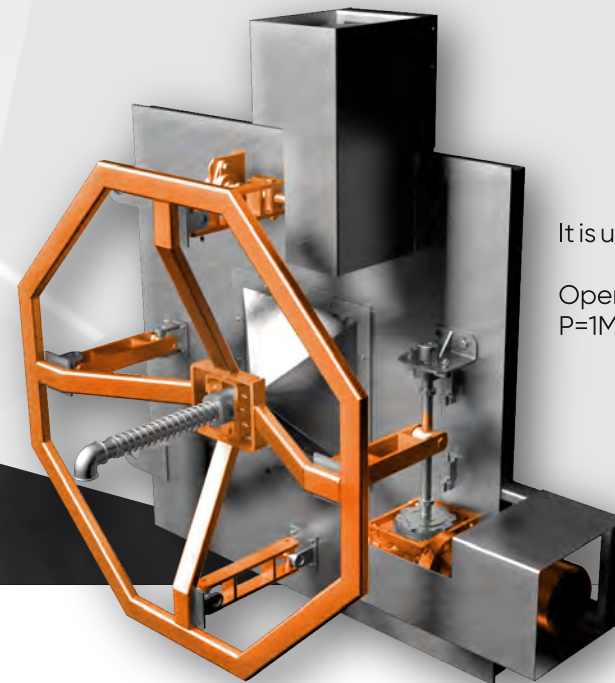

It is used for cleaning furnace walls.

Operating medium - water
P=1MPa to 3MPa and T=50°C.

ASO-WS

Short-retractable water cannon

The short-retractable water cannon is intended for cleaning furnace walls in the area of the platen steam superheater and other hard-to-reach places of the boiler furnace.

Cleaning is carried out by moving water jets with a temperature of up to 50°C and a pressure of 1MPa to 2 MPa, which are formed and sent to the surface to be cleaned by nozzles. The cleaning area is 360°. The unit is installed on the surface of the combustion chamber partition.

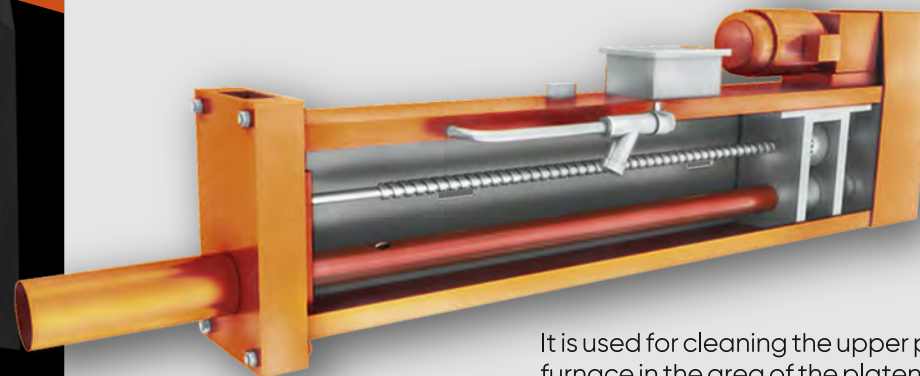

It is used for cleaning the upper parts of the furnace in the area of the platens.
Operating medium - water
P=1.0 MPa to 2.0 MPa and T= up to 50°C.

Automated process control system

Sootblower control system

The correct operation of the boiler cleaning system is directly related to the presence of an optimal control system. After identifying the needs and a detailed discussion of the customer's requirements, our specialists start working on the automation system and software development.

The basis of the control system is a PLC (programmable logic controller) the software for which is developed individually for each project. Our automation solutions are recognised as innovative, as they take into account the characteristics of the boiler and meet its specific requirements.

The careful technical planning carried out by our specialists allows you to minimise the cost of the control cabinet interface and the whole sootblower system. Implementation of the automation system is performed by qualified engineers on the basis of the most modern equipment and components of the process control system.

Taking into account the modern requirements of power plants, our control systems for the sootblowers instantly and efficiently respond to the request to change the sequence and frequency of operation of each cleaning unit. The system has extensive functionality for the recognition and evaluation of fault signals.

Creating a user interface, the company pays close attention to the ease of maintenance. Only effective and proven standards that are used in the creation of visualisation systems are introduced into production.



